



5" Type C Idlers

ICC idlers offer an exceptional combination of reliability, quality, and value in an off-the-shelf conveyor idler. Using proven seal and can designs, and heavy-duty frames, these idlers are ideal for medium duty aggregate applications.

The "Sealed for Life" bearings eliminate the need for any maintenance. The idlers are also interchangeable with a number of other manufacturer's products (See Table Below).

All ICC idlers come with a standard one-year warranty. With the best pricing in the industry, and off-the-shelf availability, these idlers are ideal for today's competitive environment.

The components are stocked in locations across the country, and are often available for delivery with minimal lead time and freight.

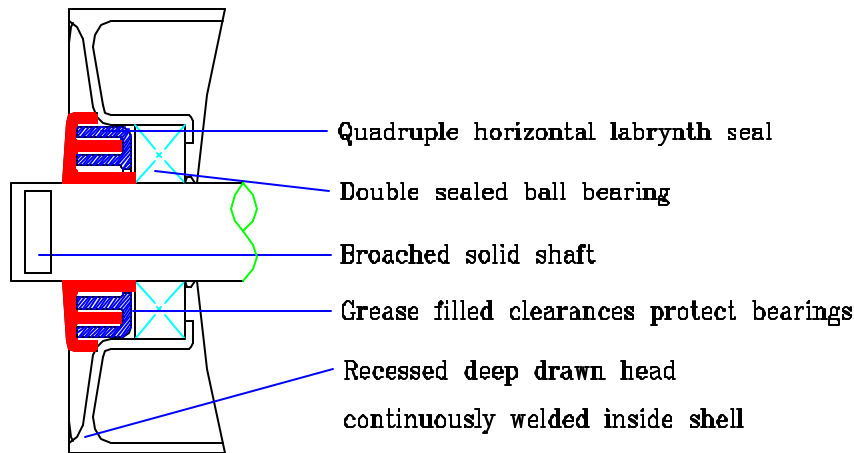

Features

Polymeric coating on roll and frames provides superior corrosion protection

"Sealed for Life" design

Labyrinth seal arrangement

Head welded inside shell

Stamped center and end brackets

Precision deep drawn head

Maximum 3/8" roll gap

20mm 6304 Ball Bearings with seals on both sides

Meets CEMA C load ratings

Meets CEMA C dimensional criteria

Broached shaft to add frame stability

Belt widths 24" through 42" (belt width + 9" mounting)

20° and 35° troughing rolls

Return idlers

Available Widths

24"

30"

36"

42"

48"

Idler Interchangeability	Series
FMC	C2000/C3000
Continental	----
Goodman (Jeffrey)	----
Hewitt-Robins	BC
Rexnord	B+
Stephens-Adamson	4400/4300
Precision	SB
Precismeca (Transall)	PC/C

DIAMOND EQUIPMENT GROUP INC.

2-8207 Swenson Way, Delta BC, V4G 1J5

Tel: 604-930-2300 Fax: 604-930-2301

www.diamondequip.com info@diamondequip.com



5" Type C Idlers

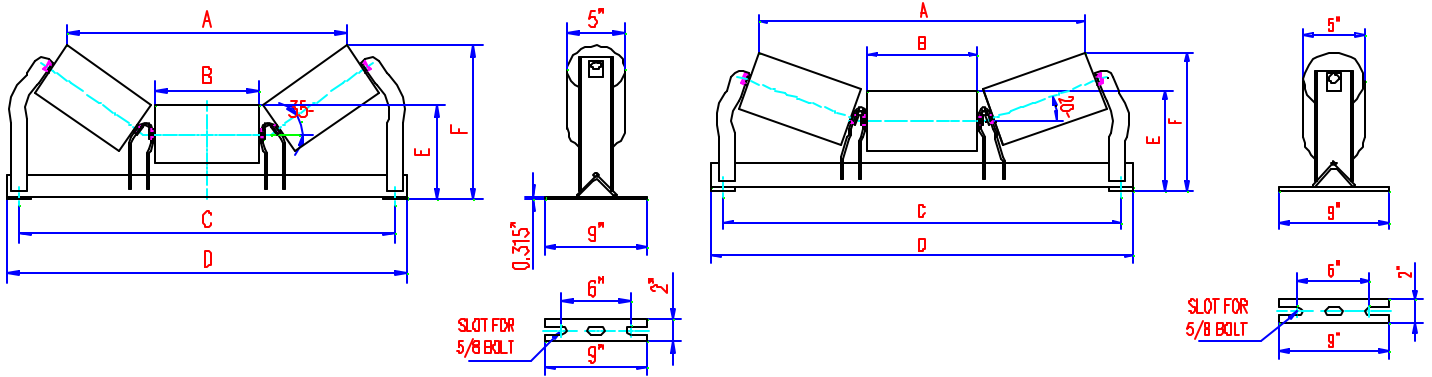

Belt Width (")	Idler Number	Idler Weight	A	B	C	D	E	F
24	C35-24	36	24 1/2	9	33	35	8 3/8	13 1/2
30	C35-30	42	29 7/8	11	39	41	8 9/16	15
36	C35-36	46	35 1/8	13	45	47	8 9/16	16 1/8
42	C35-42	52	41 3/8	15	51	53	8 9/16	17 1/2
48	C35-48	58	52	17	57	59	8 9/16	18 3/4
24	C20-24	34	27 1/8	9	33	35	8 3/8	11 1/2
30	C20-30	42	32 7/8	11	39	41	8 9/16	12 1/2
36	C20-36	43	38 9/16	13	45	47	8 9/16	13 1/8
42	C20-42	49	45 3/8	15	51	53	8 9/16	14
48	C20-48	55	52	17	57	59	8 9/16	18 3/4

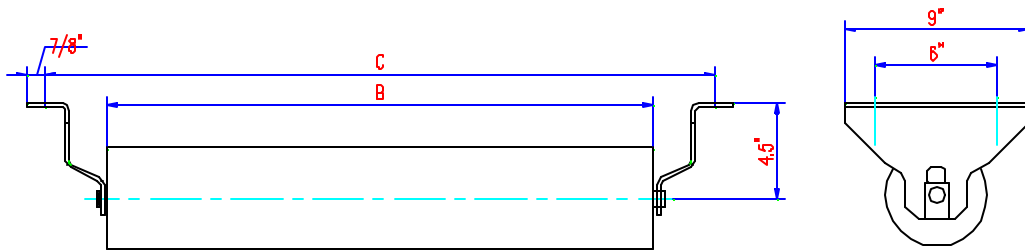

Belt Width (")	Idler Number	Idler Weight	B	C
24	CR-24	24	24 7/8	33
30	CR-30	28	32 7/8	39
36	CR-36	32	38 7/8	45
42	CR-42	36	44 7/8	51
48	CR-48	40	50 7/8	57
60	CR-60	45	54 7/8	63