



TRIO Idlers, Pulleys & Speed Reducers

IDLERS

TRIO manufactures a complete line of conveyor idlers for a wide range of applications and belt widths. These reliable, high quality idlers are used by end users and OEM conveyor manufacturers around the globe. Trio's idler product line is comprised of 4inch CEMA "B", 5 inch CEMA "C", and 6 inch CEMA "D" Idlers, available in troughing, return, impact, training, channel mount, and picking styles. Trio utilizes "Sealed for Life" bearings to eliminate the need for any maintenance. Trio idlers are also interchangeable with a number of other manufacturer's products.

CEMA B IDLERS

4" Type B Return Idlers							
Belt Width (Inch)	Idler Number	Idler Wt.		A		B	
		KG	LBS	MM	IN	MM	IN
18	BR-18	7	15	533	21	686	27
24	BR-24	8	18	686	27	838	33
30	BR-30	10	23	838	33	991	39
36	BR-36	11	24	991	39	1143	45

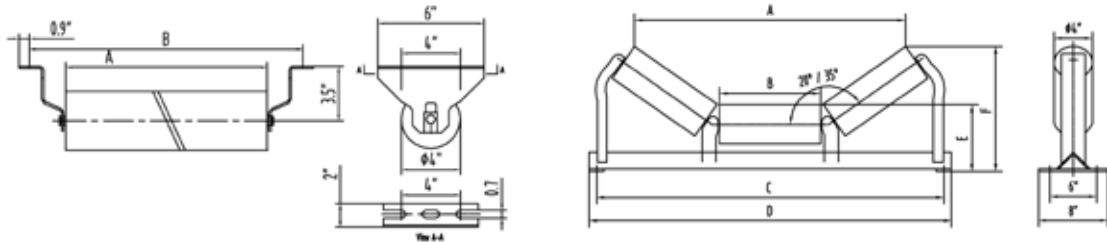

4" Type B Troughing Idlers															
Belt Width (Inch)	Idler Number	Idler Wt.		A		B		C		D		E		F	
		KG	LBS	MM	IN	MM	IN	MM	IN	MM	IN	MM	IN	MM	IN
18	B35-18	13.6	30	486	19 1/8	222	7	838	27	889	29	237	7 1/8	317	11 1/4
24	B35-24	15.9	35	622	24 1/2	277	9	990	33	1040	35	237	7 1/8	334	12 1/2
30	B35-30	17.6	39	764	30 1/16	332	11	1143	39	1193	41	237	7 1/8	353	13 5/8
36	B35-36	20.4	45	900	35 7/16	388	13	1295	45	1360	47	246	7 1/8	383	14 3/4
18	B20-18	13	29	541	21 5/16	441	7	1448	27	1513	29	246	7 1/8	400	9 5/8
24	B20-24	15.4	34	691	27 3/16	499	9	1600	33	1665	35	254	7 1/8	428	10 3/8
30	B20-30	16.7	37	843	33 3/16	552	11	1753	39	1818	41	254	7 1/8	445	11
36	B20-36	20	44	992	39 1/16	660	13	2058	45	2123	47	254	7 1/8	482	11 3/4

CEMA C IDLERS

5" Type C Return Idlers							
Belt Width (Inch)	Idler Number	Idler Wt.		A		B	
		KG	LBS	MM	IN	MM	IN
18	CR-18	9	20	531	22	686	27
24	CR-24	11	24	686	27	838	33
30	CR-30	13	28	838	33	991	39
36	CR-36	15	32	991	39	1143	45
42	CR-42	16	36	1143	45	1295	51
48	CR-48	18	40	1295	51	1448	57
54	CR-54	20	44	1448	57	1600	63
60	CR-60	22	48	1600	63	1753	69

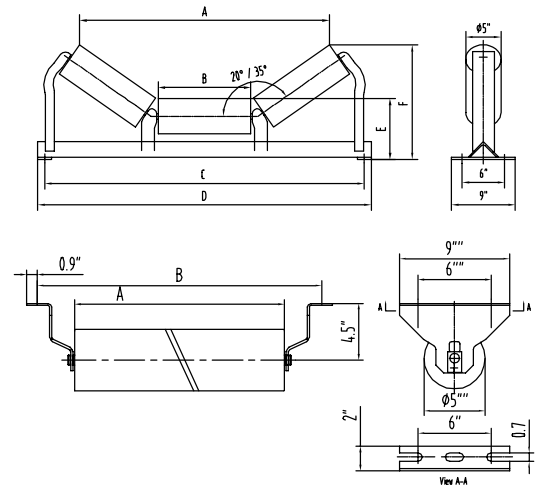

5" Type C Troughing Idlers															
Belt Width (Inch)	Idler Number	Idler Wt.		A		B		C		D		E		F	
		KG	LBS	MM	IN	MM	IN	MM	IN	MM	IN	MM	IN	MM	IN
18	C20-18	18	39	539	21 1/4	178	7	686	27	736	29	210	8 1/4	273	10 3/4
24	C35-24	21	46	622	24 1/2	229	9	838	33	889	35	213	8 3/8	343	13 1/2
30	C35-30	24	53	759	29 7/8	279	11	991	39	1041	41	217	8 9/16	381	15
36	C35-36	26	58	892	35 1/8	330	13	1145	45	1194	47	217	8 9/16	410	16 1/8
42	C35-42	31	68	1051	41 3/8	381	15	1295	51	1346	53	217	8 9/16	445	17 1/2
48	C35-48	34	75	1321	52	432	17	1448	57	1499	59	217	8 9/16	476	18 3/4
54	C35-54	37	81	1292	50 7/8	483	19	1600	63	1651	65	219	8 5/8	495	19 1/2
60	C35-60	39	86	1473	58	559	22	1753	69	1803	71	219	8 5/8	537	21 1/8
18	C20-18	19	42	487	19 1/8	178	7	686	27	736	29	210	8 1/4	314	12 3/8
24	C20-24	20	43	689	27 1/8	229	9	838	33	889	35	213	8 3/8	292	11 1/2
30	C20-30	24	52	835	32 7/8	279	11	991	39	1041	41	217	8 9/16	318	12 1/2
36	C20-36	26	57	979	38 9/16	330	13	1145	45	1194	47	217	8 9/16	333	13 1/8
42	C20-42	29	64	1153	45 3/8	381	15	1295	51	1346	53	217	8 9/16	356	14
48	C20-48	32	70	1321	52	432	17	1448	57	1499	59	217	8 9/16	378	14 7/8
54	C20-54	35	77	1416	55 3/4	483	19	1600	63	1651	65	219	8 5/8	387	15 1/4
60	C20-60	37	81	1616	63 5/8	559	22	1753	69	1803	71	219	8 5/8	410	16 1/8

FEATURES OF ALL TRIO IDLERS:

- Industry-preferred recessed end disk eliminating roll-to-end disc separation
- Grease-filled deep labyrinth seal helps eliminate contaminants within bearing
- Exterior shield provides a barrier and keeps contaminants from bearing cavity
- Precision ground lifetime greased ball bearings with positive lip contact seals

CEMA D IDLERS

6" Type DR Return Idlers							
Belt Width (Inch)	Idler Number	Idler Wt.		A		B	
		KG	LBS	MM	IN	MM	IN
36	DR-36	22.5	49.5	988	38 7/8	1143	45
42	DR-42	25.3	55.7	1140	44 7/8	1295	51
48	DR-48	28.1	61.8	1292	50 7/8	1447	57
60	DR-60	33.75	74.3	1598	62 15/16	1753	69

FEATURES FOR ALL TRIO IDLERS:

- Heavy-duty center and end stands
- Ridged self-cleaning welded steel frame
- Broached shaft to add frame stability
- Head welded inside shell
- Stamped center and end brackets

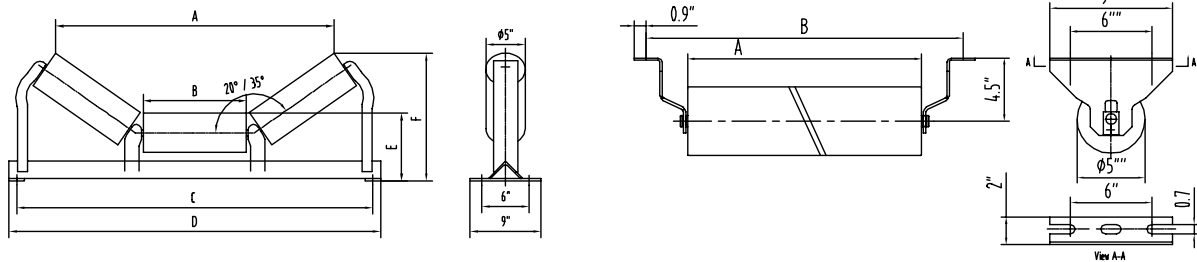

6" Type D Troughing Idlers															
Belt Width (Inch)	Idler Number	Idler Wt.		A		B		C		D		E		F	
		KG	LBS	MM	IN	MM	IN	MM	IN	MM	IN	MM	IN	MM	IN
36	D35-36	40.2	88.4	893	35 3/16	332	13 1/16	1143	45	1193	47	237	9 5/16	427	16 13/16
42	D35-42	45.4	99.9	1048	41 1/4	391	15 3/8	1295	51	1360	53 9/16	246	9 11/16	470	18 1/2
48	D35-48	51.3	112.9	1180	46 7/16	441	17 3/8	1448	57	1513	59 9/16	246	9 11/16	499	19 5/8
60	D35-60	65.6	144.3	1473	58	552	21 3/4	1753	69	1818	71 9/16	254	10	570	22 7/16

6" Type DI Troughing Idlers															
Belt Width (Inch)	Idler Number	Idler Wt.		A		B		C		D		E		F	
		KG	LBS	MM	IN	MM	IN	MM	IN	MM	IN	MM	IN	MM	IN
36	DI20-36	54.9	120.8	980	38 9/16	332	13 1/16	1143	45	1193	47	237	9 5/16	353	13 7/8
42	DI20-42	65.3	143.7	1153	45 3/8	388	15 1/4	1295	51	1360	53 9/16	246	9 11/16	383	15 1/16
48	DI20-48	73.3	161.3	1300	51 3/16	441	17 3/8	1448	57	1513	59 9/16	246	9 11/16	400	15 3/4
60	DI20-60	92.07	202.6	1613	63 1/2	552	21 3/4	1753	69	1818	71 9/16	254	10	445	17 1/2

FEATURES FOR ALL TRIO IDLERS:

- Complies with CEMA idler dimensional criteria and load ratings
- Heavy-duty center and end stands
- Sealed-for-Life design
- Precision deep drawn head
- Return idlers with drop or riser brackets



- CEMA D 6" IDLERS
- 36" - 60" BELT WIDTH IN STOCK
- 20° & 35° TROUGH, IMPACT & RETURNS

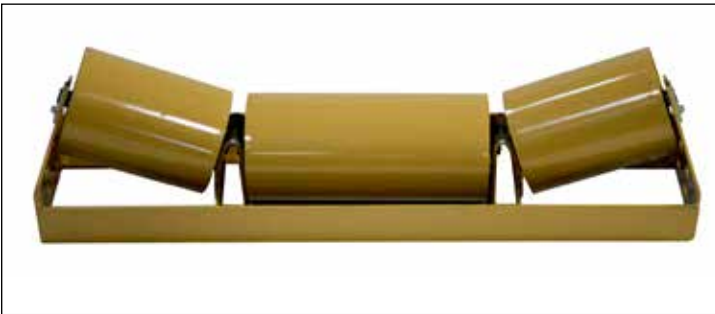

- CEMA C 5" CHANNEL MOUNT IDLERS
- 24" - 48" BELT WIDTH IN STOCK
- 20°

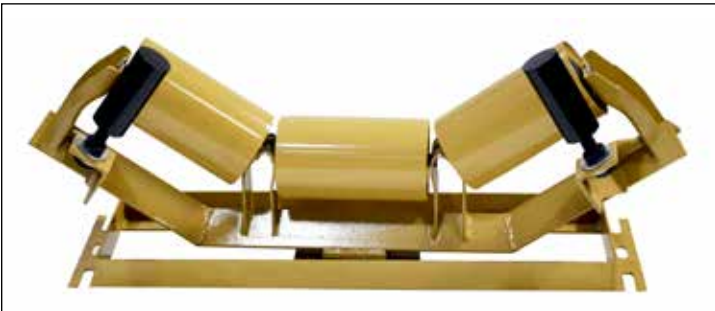

- CEMA C 5" TROUGH TRAINING IDLERS
- 24" - 48" BELT WIDTH IN STOCK
- 35°



- CEMA C 5" RETURN TRAINING IDLERS
- 24" - 48" BELT WIDTH IN STOCK

SPEED REDUCERS

TRIO speed reducers utilize corrosion resistant, ductile iron cast housings which are precision machined. A ribbed housing construction provides strong, rigid support for bearings and gearing. This design also channels oil to all bearings for superior lubrication and extended operating life while double lip seals retain oil and lock out dirt. TRIO uses a helical gear tooth design to maximize the power transfer efficiency.

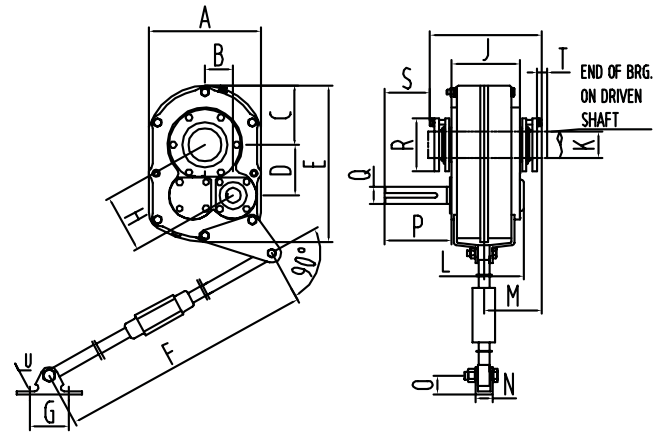

	TRIO Speed Reducers							
	Size 2	Size 3	Size 4	Size 5	Size 6	Size 7	Size 8	Size 9
A	8.38	9.25	10.38	13.13	15.13	18.75	20.25	22.63
B	2.14	2.33	2.76	3.04	4.09	5.11	6.03	6.59
C	4.09	4.84	5.50	6.56	7.56	9.38	10.03	11.31
D	3.75	4.17	4.79	5.67	6.73	8.3	9.5	10.81
E	11.41	12.88	15.13	18.31	21.31	25.94	28.25	31.69
F	26.94-32.94	26.94-32.94	29.19-35.19	29.19-35.19	29.19-35.19	29.44-35.44	30.00-36.00	30.00-36.00
G	3.00	3.00	4.00	4.00	4.75	4.75	7.00	7.00
H	4.32	4.78	5.53	6.43	7.88	9.74	00.25	12.66
I	7.32	9.22	9.98	10.52	11.53	12.85	14.03	14.12
J	4.5	5.63	6.13	6.31	6.88	7.75	8.37	8.12
K	1 15/16	2 3/16	2 7/16	2 15/16	3 7/16	3 15/16	4 7/16	4 15/16
L	2.82	3.30	3.14	4.45	4.57	4.69	5.85	5.66
M	3.68	4.52	4.79	5.05	5.73	6.38	7.04	7.04
N	1.25	1.25	1.44	1.44	2.75	2.75	4.00	4.00
O	1.06	1.06	1.75	1.75	2.00	2.00	3.13	3.13
P	3.59	4.34	5.57	5.74	6.08	6.35	7.11	9.65
R	4.06	4.38	4.81	5.63	6.13	7.25	7.75	8.75
S	2.22	2.34	3.44	3.44	3.73	4.31	4.31	6.63
T Min	1.25	1.50	1.75	1.81	1.81	2.06	2.06	2.44
U	0.44	0.44	0.50	0.50	0.63	0.75	0.75	0.75
Diam. Shaft	1.13	1.25	1.44	1.94	2.19	2.44	2.44	2.44
Keyed Shaft	.25x.13x2.50	.25x.13x2.88	.38x.19x4.06	.50x.25x4.50	.50x.25x4.50	.63x.31x4.75	.63x.31x5.38	.63x.31x7.75

TRIO reducers mount directly on driven shaft, eliminating the need for coupling or chain drive. The sliding motor base and support structure eliminate alignment problems. Twin taper bushings eliminate play between the reducer and shaft. No set screws to score or gouge the shaft. TRIO torque arm reducers can be positioned anywhere along the driven shaft in horizontal, vertical and inclined positions for greater installation ease.

PULLEYS

TRIO offers both head pulleys and heavy-duty fabricated tail pulleys. These heavy-duty pulleys use engineered end discs, standard XT style bushings for attachment on shafting, machined crowns and vulcanized lagging.

Crowned Wing Tail Pulley

Dia.	Face Width	Hub	Weight LBS
8"	20"	25	66
8"	26"	25	86
8"	32"	25	106
8"	38"	25	127
10"	20"	25	80
10"	26"	25	101
10"	32"	25	129
10"	38"	25	153
10"	44"	30	218
10"	51"	30	235
12"	20"	25	90
12"	26"	25	122
12"	32"	25	153
12"	32"	30	181
12"	38"	25	179
12"	38"	30	214
12"	44"	30	204
12"	51"	30	288
12"	63"	30	347
14"	26"	25	160
14"	26"	30	170
14"	32"	25	196
14"	32"	30	199
14"	38"	25	234
14"	38"	30	243
14"	44"	30	271
14"	51"	35	330
14"	63"	35	414
16"	26"	25	198
16"	26"	30	185
16"	32"	25	220
16"	32"	30	228
16"	38"	30	260
16"	38"	35	266
16"	44"	35	317
16"	51"	35	361
16"	63"	40	414
18"	26"	30	222
18"	32"	35	280
18"	38"	35	310
18"	44"	35	356
18"	44"	40	362
18"	51"	40	440
20"	26"	35	253
20"	32"	35	310
20"	38"	40	364
20"	44"	40	428
20"	51"	40	497

Crowned Lagged Drum Pulley

Dia.	Face Width	Hub	Weight LBS
8"	20"	25	60
8"	26"	25	70
8"	32"	25	85
8"	38"	25	100
10"	20"	25	75
10"	26"	25	90
10"	32"	25	110
10"	38"	25	135
10"	44"	30	150
10"	51"	30	160
12"	20"	25	95
12"	26"	25	125
12"	26"	30	130
12"	32"	25	140
12"	32"	30	145
12"	38"	25	170
12"	38"	30	175
12"	44"	30	220
12"	51"	30	250
12"	63"	30	275
14"	26"	25	155
14"	26"	30	160
14"	32"	25	175
14"	32"	30	180
14"	38"	25	205
14"	38"	30	210
14"	44"	30	240
14"	51"	35	315
14"	63"	35	390
16"	26"	25	175
16"	26"	30	180
16"	32"	35	185

Crowned Lagged Drum Pulley

Dia.	Face Width	Hub	Weight LBS
16"	32"	25	230
16"	32"	30	235
16"	32"	35	240
16"	38"	30	250
16"	38"	35	255
16"	44"	30	270
16"	44"	35	257
16"	51"	35	320
16"	63"	40	360
18"	26"	30	235
18"	26"	35	240
18"	32"	35	250
18"	32"	40	255
18"	38"	35	290
18"	38"	40	300
18"	44"	35	340
18"	44"	40	350
18"	51"	40	415
20"	26"	35	270
20"	32"	40	290
20"	32"	50	345
20"	38"	35	325
20"	38"	40	478
20"	38"	50	498
20"	44"	50	541
20"	51"	50	551
24"	26"	40	440
24"	32"	40	520
24"	32"	50	530
24"	38"	45	645
24"	38"	50	655
24"	44"	50	750
24"	51"	50	900

Crowned Smooth Steel Drum Pulley

Dia.	Face Width	Hub	Weight LBS
10"	20"	25	66
10"	26"	25	77
10"	32"	25	87
10"	38"	25	98
12"	26"	25	110
12"	26"	30	111
12"	32"	25	123
12"	32"	30	128
12"	38"	30	139
14"	26"	25	139
14"	32"	30	168
14"	38"	30	177
14"	44"	30	183
16"	32"	30	267
16"	38"	35	304
18"	32"	35	248
18"	38"	35	261

FEATURES:

- Machined crowns
- Vulcanized lagging
- Heavy duty fabricated tail pulleys
- High strength end discs
- Standard XT style bushings for attachment on shafting
- XT hubs
- Heavy duty flat bar wing design
- Available in a wide range of standard sizes



CRUSHERS

CT Series Jaw
TC Series Cone
APS Series Impact
APP Series Impact
TV Series Impact
T Series Cone

Screens

TIH Series Inclined
TIO Series Inclined
TIOSP Series Inclined
TTH Series Horizontal
TBSS Series Banana
TBSD Series Banana

Portable Plants

Track Mounted
Wheel Mounted

Plant Solutions

Turn-key Projects
Modular Systems

TRIO - US

Corporate Office
12823 Schabarum Ave.
Irwindale, CA 91706
United States
Tel +1 626 851 3966
Fax +1 626 851 9526
productinfo@trioproducts.com

