

**WARMAN®**  
Centrifugal Slurry Pumps

Excellent  
Minerals  
Solutions

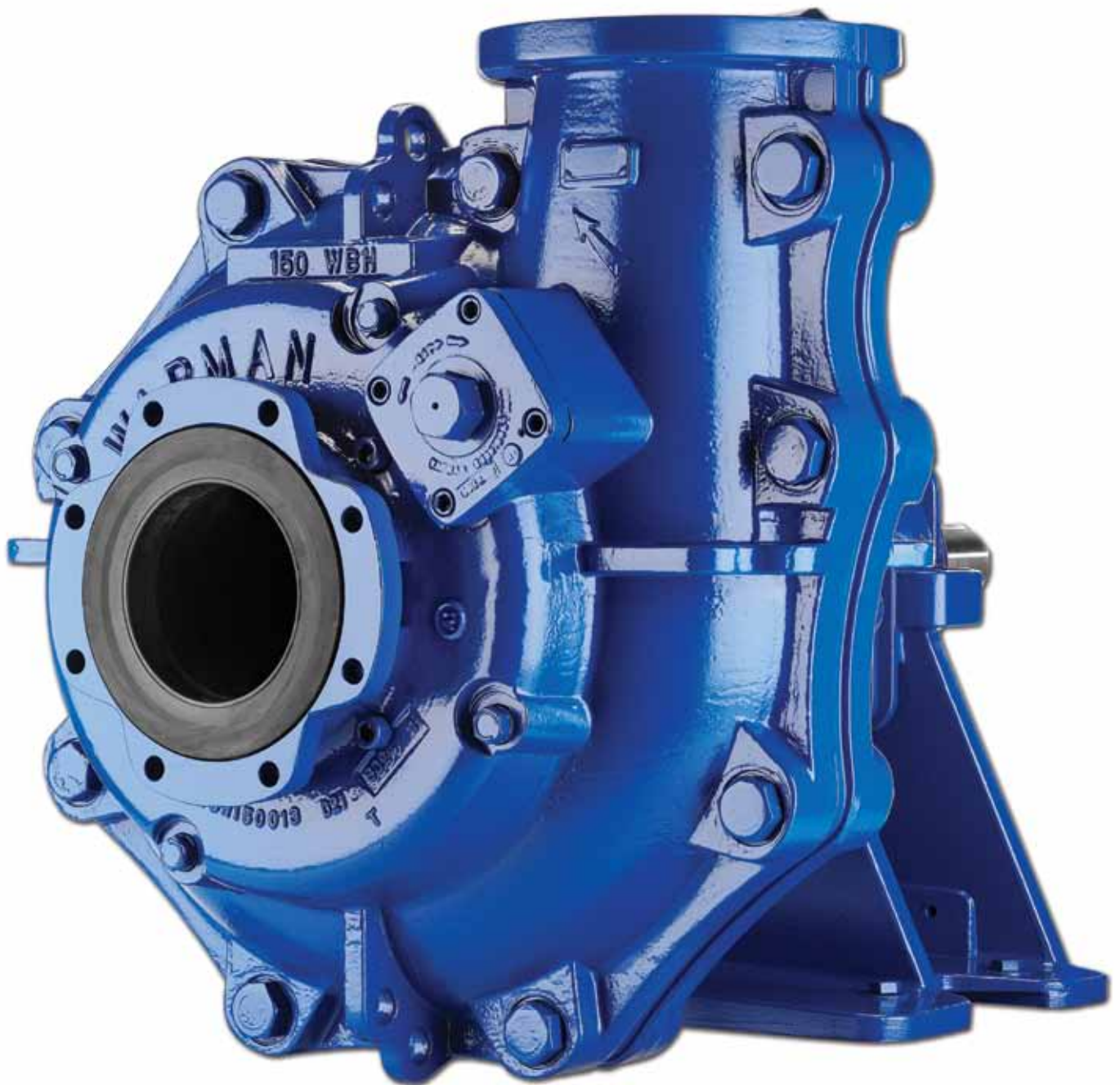

**WBH® Centrifugal Slurry Pump**



**DIAMOND**  
diamondequip.com

**Put yourself in the driver's seat with the revolutionary new Warman® WBH® centrifugal slurry pump.**

**Compared with the current horizontal slurry pump technology\*, this pump can offer:**

**Less maintenance.**

**Less power usage.**

**Longer wear life.**

**Higher performance.**

There would be few people involved in slurry pumping who wouldn't be familiar with the Warman® AH™ slurry pump and the many innovative enhancements and material improvements which Weir Minerals has developed to meet the productivity and cost demands of customers in all types of operating environments.

This development has extended over four decades, providing Weir Minerals with a vast knowledge bank in slurry pumping technology. So by putting our heads together on a global basis, by understanding the needs of customers today, and by the aid of Computational Fluid Dynamics design, Weir Minerals has created the ultimate slurry pump - one that



gives you greater control over the performance and maintenance of your pump, reducing costs and keeping production running.

**It's the revolutionary new Warman® WBH® centrifugal slurry pump.**

*\* When compared with the Warman® AH™ centrifugal slurry pump.*



## Maintenance magic with a fully adjustable throatbush while running.

The days of uneven and premature wear that result in disrupted production will become a thing of the past with this quantum leap in front liner design. With just a single action you can now adjust the throatbush front liner both rotationally and axially, and at the same time. The new WBH® slurry pump puts you in the driver's seat when it comes to minimising the wear in the front liner because you can adjust the throatbush to close the clearance between it and the impeller. All in all, you'll be well ahead, as you can now maintain the pump's performance and efficiency close to that of a pump in new condition, and reduce wear from a single point of adjustment.

## A whole list of advances from wet end to drive end.

A single-action fully adjustable throatbush might seem enough on its own in making maintenance easier, but Weir Minerals did not stop there in creating the new WBH® slurry pump. Weir Minerals looked at every aspect of maintenance ease, operating cost and safety, and this work resulted in a whole list of advancements from the front liner to the drive end. For example, with the WBH® pump, there is no need to check or readjust the drive every time an adjustment is made like with the AH™ pump.



'One-point' adjustment device to rotate and axially move the cover plate liner closer to the impeller. This will minimise the front impeller gap, hence reducing recirculation, which leads to extended wear and maintains performance.



## "It's definitely the pump of the future."

Commitment to improvement is a major focus for Coal & Allied's operations in the Hunter Valley of NSW, Australia. This involves constant reviews of operational procedures and an emphasis on sharing knowledge and experience. So when they had the chance to tap into the comprehensive knowledge bank of Weir Minerals - by way of an invitation to trial the new Warman® WBH® centrifugal slurry pump - staff at C&A's Mount Thorley Warkworth open cut Hunter Valley mine welcomed the opportunity.

Installation of the pump in the southern coal handling preparation plant, under the instruction of Weir Minerals' Area Manager, proceeded as smoothly as anyone could wish. "The Weir Minerals team arranged everything," said Paul Burgess, CHPP Reliability Engineer at the time. "All the necessary design changes went to plan and it took only about eight to ten hours to swap it over."

Six months later, the WBH® pump received approval ticks in all boxes. Among its advantages are reduced energy usage, ease of maintenance and enhanced performance. "It's definitely using less power than the previous pump," said Paul. "There are also big advantages in its design features, such as the one-piece bearing frame, which keeps the shaft in line. No shaft adjustment is needed, so there's no damage to mechanical seals because of misalignment."

Mechanical Planner Ged Mungoven said Weir Minerals' WBH® pump was outperforming others at the mine. "I can't say a bad thing about it," he said.

Impressed by the WBH® pump's performance, they ordered five for the site's north plant. "We're having a few mechanical ratings problems with the underflow pumps there, but the new pumps will address that issue," said Paul. "It's definitely the pump of the future."

The new Warman® WBH® centrifugal slurry pump proves itself as "the pump of the future" at Coal & Allied's Mount Thorley Warkworth operation, Australia.

**A giant step forward in power savings>**

**Wear life under your control>**

**Smoothing the flow of slurry>**

**Keeping the pressure up>**



## A giant step forward in power savings

As the cost of power and carbon reduction becomes increasingly critical to your business, the new WBH® slurry pump is designed to make big inroads in cost reduction for you. By keeping the gap between the impeller and throatbush minimised with the fully adjustable throatbush, having a drive end that keeps aligned to the front liner, creating a shaft and casing that stays aligned to extend the life of mechanical seals, and having an integral (one-piece) bearing frame and a new concept in impeller and volute design, you'll have your power costs not only well under control, but well down.

## Wear life under your control

Computational Fluid Dynamics methods played a vital role in the development of the WBH® slurry pump's wear resistant features. When you adjust your throatbush while running with a single action whenever you want, you'll be spreading the throatbush wear more evenly, extending its life. The unique new impeller and volute design minimises turbulence so that wear becomes more predictable. And with a robust one-piece bearing frame for accurate alignment, it will keep your bearings going longer.

## Smoothing the flow of slurry

Considered a revolution in impeller and volute design, the new WBH® slurry pump replaces the uneven wearing of the past caused by unwanted vortices with a unique patented design based on a vanelet in each impeller channel, and a four-vane impeller as standard to streamline the slurry flow through the pump. No longer impeded by the need to stop production or ramp up speed to catch up because of these vortices between the impeller and volute, power usage, maintenance costs and pump performance will follow a smoother path.

## Keeping the pressure up

The ability to withstand the demands of high pressure wherever it is faced in the slurry pump flow has been incorporated into the new WBH® slurry pump design right down to the smallest detail.

Beginning with the biggest advancement of them all, the drive end has a strong and rigid one-piece bearing frame to keep the bearings aligned all the way through to the front liner, minimising vibrations and distortions from external piping loads. Then there are the large capacity bearings that mean you can handle high loads including thrust and endure the test of time. The bearing end cover seals are a commercial labyrinth style that both seal out the dirt and slurry and keep in the lubrication. Gone is the need for the regular bearing labyrinth grease purging used on the AH™ pumps.

In the front liner, There's a large diameter Warman Hi-Seal® -style expeller as an option for sealing against high intake pressures without gland seal water. All rubber and metal liners are high pressure rated with rubber liners encapsulated within to prevent liner extrusion or blow-out.

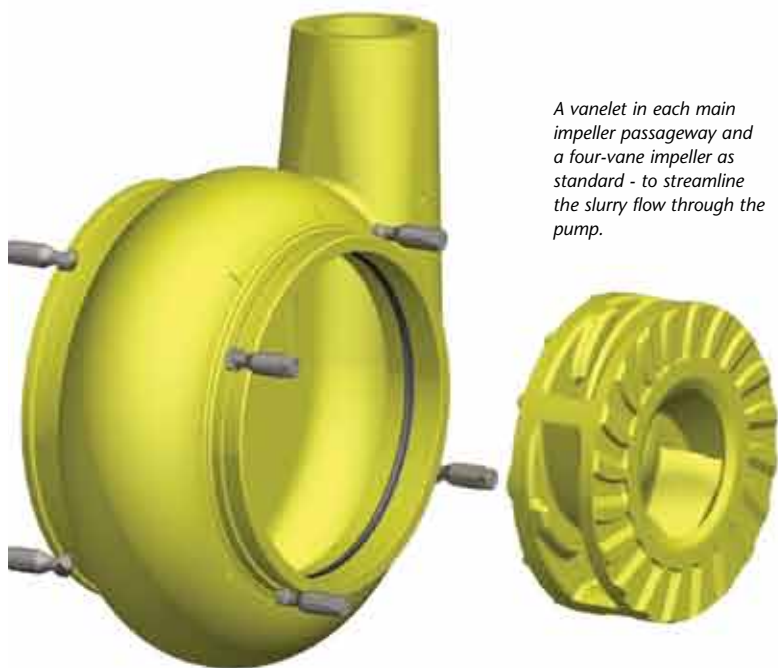

*A vanelet in each main impeller passageway and a four-vane impeller as standard - to streamline the slurry flow through the pump.*



*New integral (one-piece) WBH® bearing frame design for correct alignment of bearings, seal and impeller to front liner. Less part count. More robust.*



*L-R Paul Sharp and Matt Cosgrove from Sibelco Australia enjoy the many benefits of the WBH® slurry pump at the Tallawang mine site in NSW, Australia.*

### ***“The pump ran beautifully from Day One.”***

Sibelco Australia takes pride in using innovative methods and sophisticated equipment in its work of processing and supplying raw materials for the Australian, New Zealand and Asian manufacturing and primary industries. Its Tallawang mine in central western NSW was therefore a natural choice for the world-first trial of Weir Minerals’ new Warman® WBH® centrifugal slurry pump.

The trial began in December 2009, with Weir Minerals staff helping with the installation. It was a trouble-free process, even with the need to make up a base plate for the WBH® pump to bring it to the same height as its predecessor, a Warman® AH™ pump. *“We’d allowed two days for the changeover but it was done in one day,”* said maintenance supervisor, Matt Cosgrove. *“And the pump ran beautifully from Day One with no dramas whatsoever.”*

Since then, hopes for the performance of the WBH® pump have been realised.

*“It runs cooler and uses less power, and we can adjust it on the run, which couldn’t be done with the previous pumps,”* said Matt. *“To adjust them we would have had to shut the plant down for several hours.”*

With the pump wearing out in the expected time, Weir Minerals staff then performed a complete rebuild onsite in one day, serving the additional purpose of training mine staff to perform the task in the future.

*“We had no hesitation in purchasing the pump at the end of the trial in December,”* said Matt. *“And while we’re very happy with it, we’re all still learning about it, so it’s good to know ongoing support and service is available from Weir Minerals whenever we need it.”*

**The new Warman® WBH® centrifugal slurry pump gives you greater control over the performance, maintenance and safety of your pump.**

<b>WARMAN® WBH® CENTRIFUGAL SLURRY PUMP IMPROVED PRODUCTIVITY, MAINTENANCE AND SAFETY BENEFITS TABLE (comparison with the Warman® AH™ pump)</b>
Fully adjustable throatbush while running
Turbulence-minimising volute and four-vane impeller
Lower wear rate of impeller and throatbush due to more streamlined flow
Lower wear rate maintains internal profiles longer, maintaining lower turbulence over time
High efficiency from the start due to Computational Fluid Dynamic analysis design and turbulence minimising principles
Much lower NPSH cavitation characteristic with four-vane impeller allowing wider range of pump inlet conditions resulting in less effect (degradation) of the pump's performance
Strong and rigid one-piece bearing frame ensuring better component alignment
Bearing frame uses either grease or oil lubrication
Large diameter Warman Hi-Seal®-style expeller for sealing high intake pressures without gland seal water
Commercial labyrinth-style bearing end cover seals to keep dirt out and lubricant in and that require no external purging
Large capacity and robust bearings that can handle high loads including thrust and can run at high speeds
High pressure rated metal and rubber liners including encapsulation for rubber liners to prevent liner extrusion or blow-out
Interchangeable mixture of both metal and rubber wear components in the one pump casing
Impeller release collar in larger sized models for low-torque impeller removal
Lifting lugs on all major components and lifting tools that fit both new and worn wearing components
External ribs that assist in transferring heat and keeping bearings cool
Reversible and slip-fit shaft sleeve
Rigid overhung shaft with short overhang and large diameter shaft to minimise shaft deflection and improve mechanical seal life
No fine threads and unique liner fixing method reduces assembly time
Self-aligning pump casing halves prevent movement and dislodgement of elastomer liners during assembly
Once installed and aligned, bearings and drive remain fixed
Non-metallic split lantern ring for ease of removal and replacement without dismantling the pump
Minimal parts and minimal large bolts
Three-point lift for the bare shaft pump
Improved assembly and disassembly procedures
Leak detection as standard
Vibration, temperature and wear monitoring optional

Up to 12% power savings in WBH® pump trials.\*



**Paul Sharp from Sibelco Australia's Tallawang site in NSW, Australia, adjusts the revolutionary new Warman® WBH® pump without stopping production.**

<b>REDUCED MAINTENANCE /EASIER MAINTENANCE</b>	<b>REDUCED POWER USAGE</b>	<b>LONGER LIFE OR WEAR</b>	<b>HIGHER PERFORMANCE / BETTER SLURRY MANAGEMENT</b>	<b>IMPROVED SAFETY</b>
●	●	●	●	
●	●	●	●	
●	●	●	●	
●	●	●	●	
●	●	●	●	
●	●	●	●	
●			●	●
●				●
●			●	
●		●	●	
●		●		●
		●		●
●				●
●				●
●		●		
●		●		
●		●	●	
●				●
●		●		
●			●	
●				●
●				●
●				●
●				●
●				●
●				●
●				●
●				●
●				●
●				●
●				●
●				●
●				●
●				●



**Quick and easy disassembly:**  
 Front sub-assembly easily removed for maintenance - volute liner attached to cover plate. Four camlocks hold liner into cover plate. No troublesome threads.



**Better alignment. Fewer parts. More robust:**  
 A strong and rigid one piece bearing frame ensures better component alignment. Large capacity and robust bearings that can handle high loads including thrust and can run at high speeds.

\* Up to 12% power saving achieved in Warman® WBH® pump trials at CSA, Australia, compared with Warman® AH™ pump in same duty.

**Grease or oil bearing lubrication**

with labyrinth-style bearing seals.

**Multiple seals available:**

gland seal, mechanical seal or large diameter expeller seal available.

**Internal liners can be fully worn**

before replacement as the ductile iron split outer casing provides structural strength to contain all design operating pressures regardless of the worn condition of the liner.

**Simple camlocks**

hold liners into casing. No troublesome studs and threads

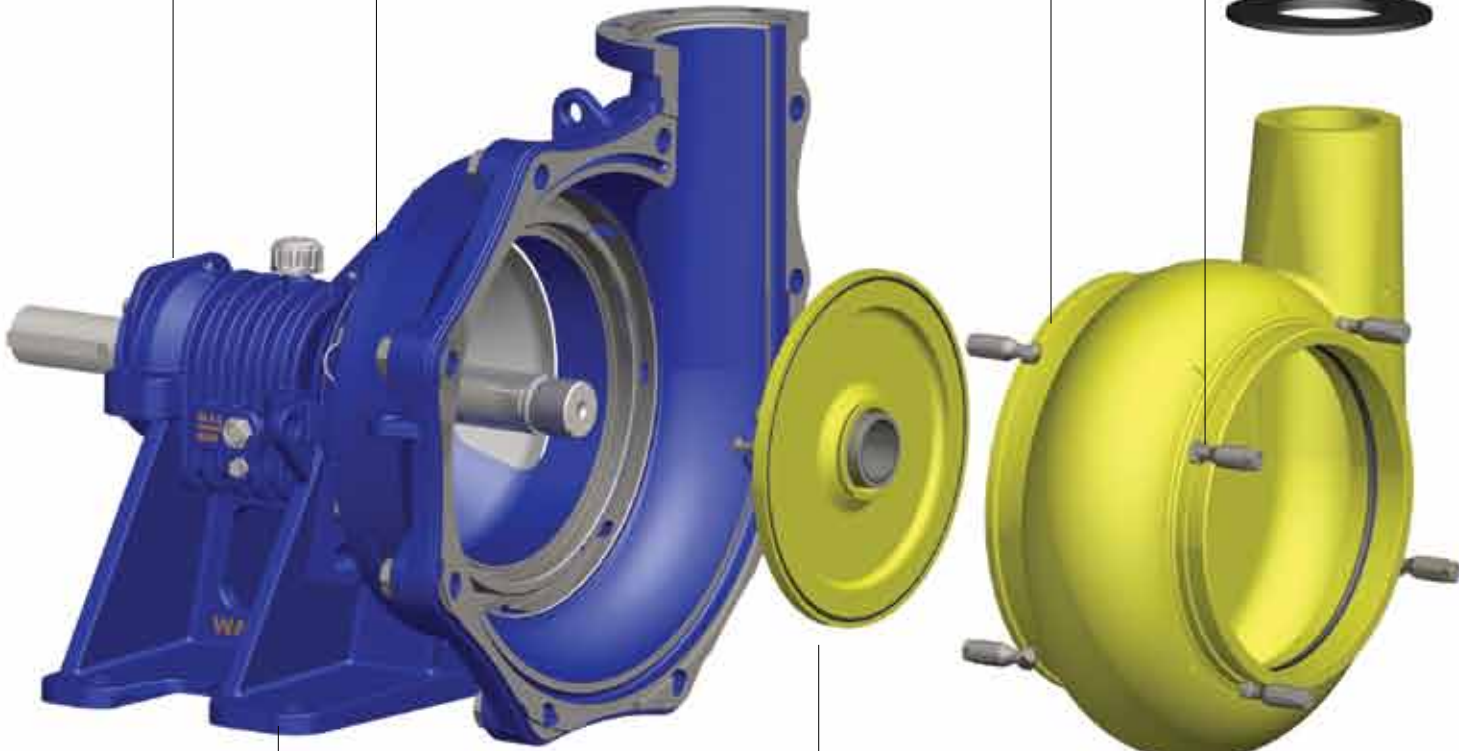

**Interchangeable metal liners and impeller**

**One piece bearing frame**

for better alignment of bearings, seal and impeller to front liner. Less part count, more robust.

**Interchangeable elastomer liners and impeller**





**The new Warman® WBH® centrifugal slurry pump — meeting the productivity and cost demands of customers in all types of operating environments.**

**One-point front liner adjustment** can be carried out with pump running. Unique axial and rotational movement minimises front impeller gap to reduce wear and maintain performance.

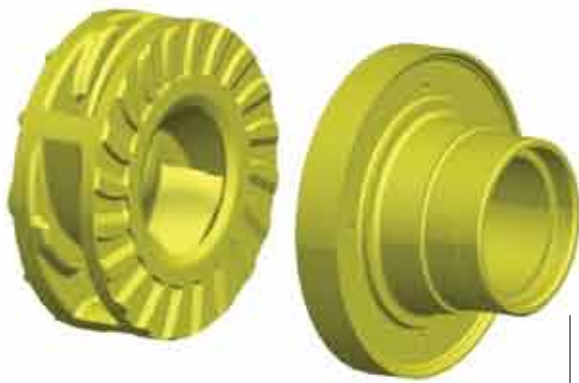

**Interchangeable metal liners and impeller**



**Interchangeable elastomer liners and impeller**



# Product selection and specification

## Warman® WBH® slurry pumps - outline dimensions

To be used for preliminary selection only. All measurements in mm.

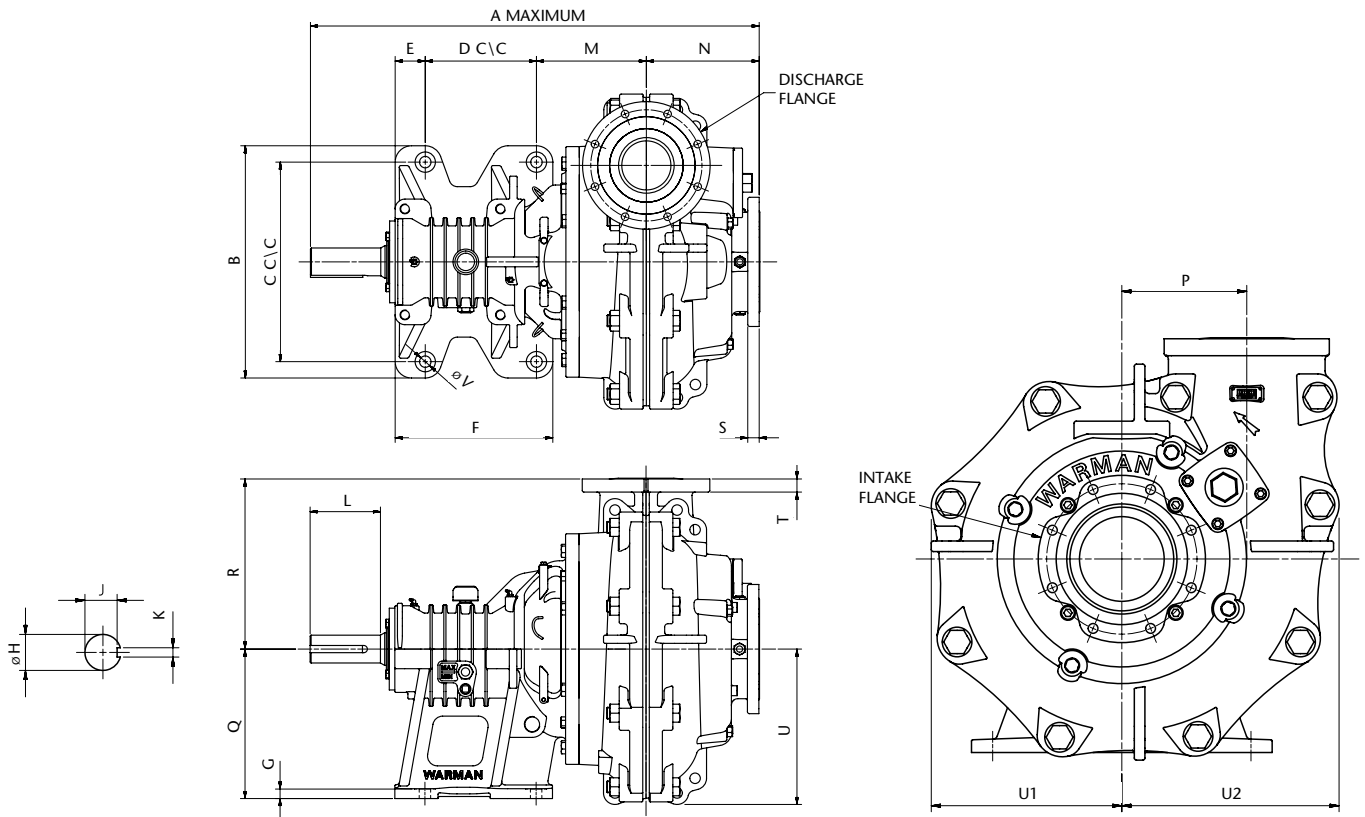

Note: Dimensions A, N, R, S and T include compression of Warman® rubber joints.

Pump Size	Base Dimensions							Discharge Flange				Intake Flange			
	A	B	C	D	E	F	G	O.D	No. of Holes	Hole Dia	P.C.D	O.D	No. of Holes	Hole Dia	P.C.D
50 NC-WBH	772	330	280	230	25	280	20	220	4	18	155	215	4	18	170
75 NPC-WBH	832	330	280	230	25	280	20	280	8	18	235	280	8	18	235
75 PC-WBH	890	430	370	230	55	315	20	280	8	18	235	280	8	18	235
100 PQC-WBH	956	406	356	175	55	269	20	305	4	23	260	325	8	23	280
100 QC-WBH	1109	540	470	300	65	400	25	305	4	23	260	325	8	23	280
150 QRC-WBH	1201	502	432	213	49	297	25	390	8	23	340	395	8	23	355
150 RC-WBH	1372	710	610	340	92	482	30	390	8	23	340	395	8	23	355
200 RSC-WBH	1499	638	546	257	85	388	30	490	8	27	440	525	8	33	470
200 SC-WBH	1766	1000	850	460	135	670	40	490	8	27	440	525	8	33	470
250 SC-WBH	1836	1000	850	460	135	670	40	550	12	23	495	610	12	27	550
300 TC-WBH	2317	1120	960	640	156	876	45	630	12	23	570	660	12	23	600

Pump Size	Pump Head Dimensions										ØV	Mass kg Metal Lined	Mass kg Rubber Lined
	M	N	P	Q	R	S	T	U	U1	U2			
50 NC-WBH	202	190	120	197	266	22	20	270	265	280	18	221	190
75 NPC-WBH	222	230	160	197	330	24	24	340	335	350	18	398	328
75 PC-WBH	228	230	160	250	330	24	24	340	335	350	19	460	390
100 PQC-WBH	302	275	205	254	400	28	30	385	395	435	23	707	562
100 QC-WBH	272	275	205	300	400	28	30	385	395	435	23	780	670
150 QRC-WBH	398	345	295	330	520	35	40	475	450	513	33	1479	1122
150 RC-WBH	336	345	295	457	520	35	40	475	450	513	33	1680	1400
200 RSC-WBH	478	420	355	457	650	36	42	670	590	715	45	2856	2717
200 SC-WBH	428	420	355	610	650	36	42	670	590	715	45	3410	2900
250 SC-WBH	442	476	425	610	715	43	50	750	734	790	45	4514	3650
300 TC-WBH	547	555	485	610	810	45	50	848	855	918	51	6840	5730

Pump Size	Drive End Shaft Dimensions				
	ØH	J	K	L	KEY
50 NC-WBH	35,03/35,01	30,00/29,80	10,00/9,96	100	10 x 8
75 NPC-WBH	35,03/35,01	30,00/29,80	10,00/9,96	100	10 x 8
75 PC-WBH	45,02/45,01	39,50/39,30	14,00/13,96	115	14 x 9
100 PQC-WBH	45,02/45,01	39,50/39,30	14,00/13,96	115	14 x 9
100 QC-WBH	60,03/60,01	53,20/53,00	18,00/17,96	150	18 x 11
150 QRC-WBH	60,03/60,01	53,20/53,00	18,00/17,96	150	18 x 11
150 RC-WBH	85,04/85,01	76,00/75,80	22,00/21,95	215	22 x 14
200 RSC-WBH	85,04/85,01	76,00/75,80	22,00/21,95	215	22 x 14
200 SC-WBH	120,04/120,01	109,00/108,80	32,00/31,94	280	32 x 18
250 SC-WBH	120,04/120,01	109,00/108,80	32,00/31,94	280	32 x 18
300 TC-WBH	150,06/150,04	138,02/137,72	36,00/35,94	350	36 x 20

## Product selection and specification

### Warman® WBH® slurry pumps - quick selection guide

Approximate clear water performance - to be used for preliminary selection only.

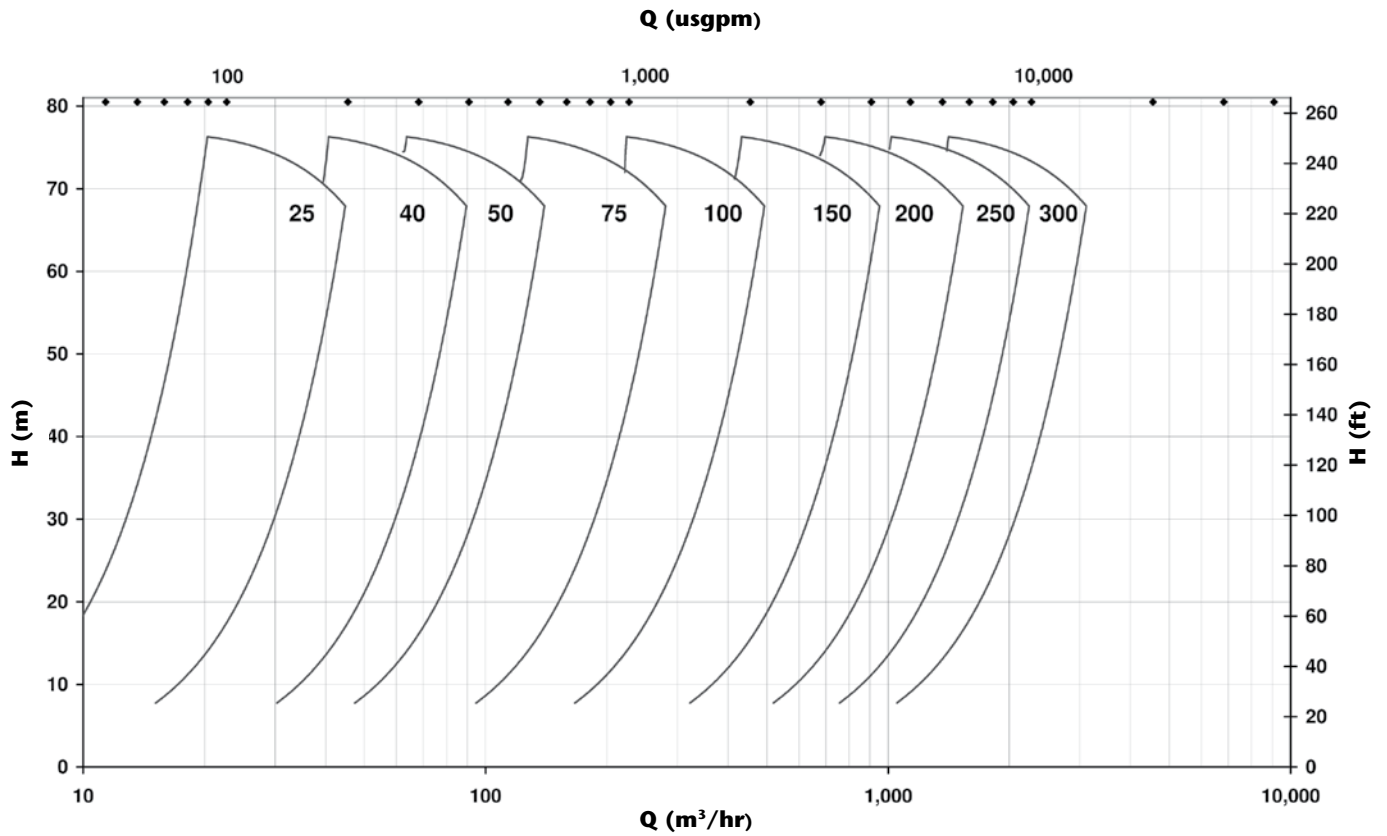

The brand that defined performance now redefines it.  
The revolutionary new Warman® WBH® centrifugal slurry pump.



**Weir Minerals products, services and expertise — meeting the needs of the global mining sector.**

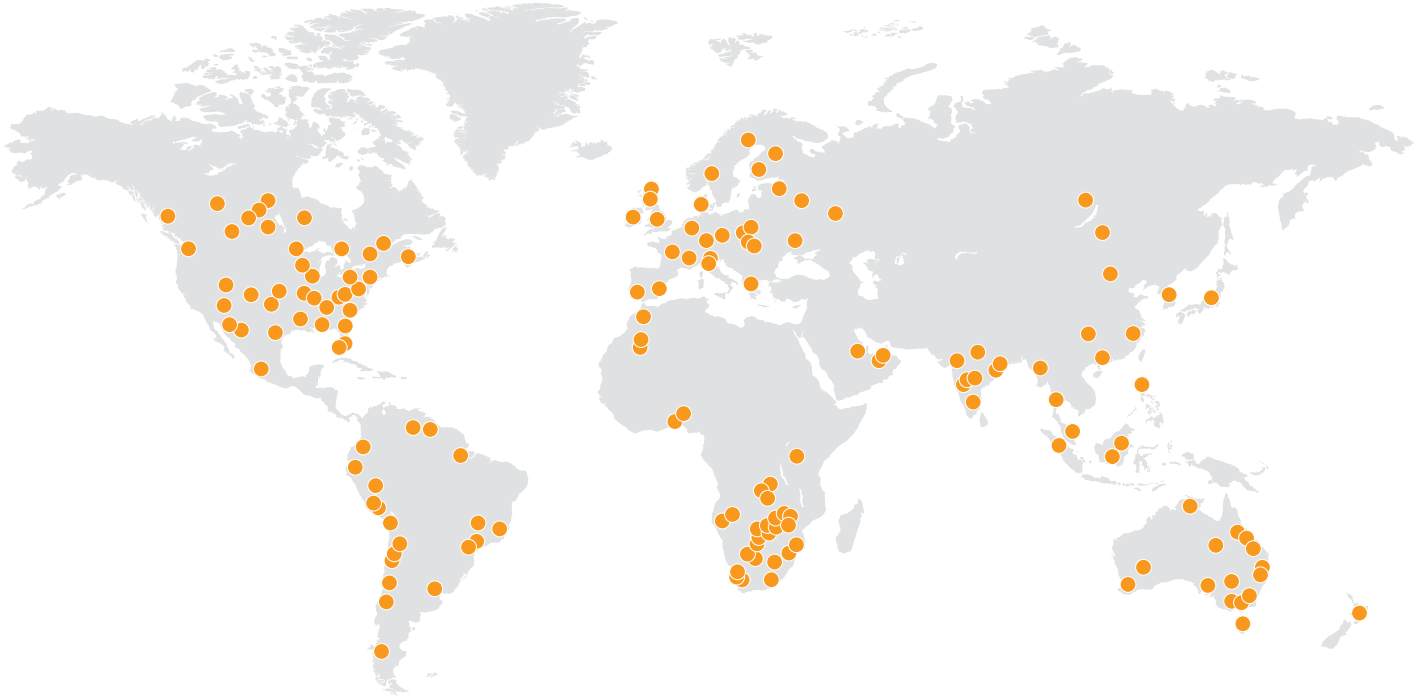

**WARMAN®**  
Centrifugal Slurry Pumps

**GEHO®**  
PD Slurry Pumps

**LINATEX®**  
Rubber Products

**VULCO®**  
Wear Resistant Linings

**CAVEX®**  
Hydrocyclones

**FLOWAY® PUMPS**  
Vertical Turbine Pumps

**ISOGATE®**  
Slurry Valves

**MULTIFLO®**  
Mine Dewatering Solutions

**HAZLETON®**  
Specialty Slurry Pumps

**LEWIS® PUMPS**  
Vertical Chemical Pumps

**WEIR MINERALS SERVICES™**



**Weir Minerals Australia Ltd**

1 Marden Street  
Artarmon NSW 2064  
Australia

Tel: +61 2 9934 5100  
Fax: +61 2 9934 5201

[www.weirminerals.com](http://www.weirminerals.com)

Excellent  
Minerals  
Solutions

